

# Hold Down and Height Adapters

## OPTIMA® GROUP 75/25

The OPTIMA 75/25 battery may be shipped with a height adapter installed. It may be needed in one of 2 ways for installation:

1. In vehicles with a top holddown where more height is required, it should be used in its original position.

2. In some Ford, Lincoln, and Mercury installations (replacing a group 65 battery) the bottom holddown of the battery must be made wider. For these installations, remove the adapter and detach the two strip adapters which are located inside. Snap these strips into the openings on either side of the battery base and discard the remainder. If the adapter is not needed for installation, it may be discarded.

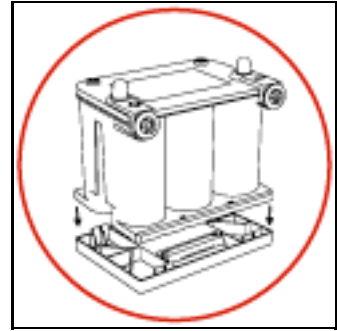

## OPTIMA GROUP 34/78

The wing adapters available for the OPTIMA 34/78 may be needed for some Ford, Lincoln, or Mercury applications (replacing a group 65). Attach these wing adapters by snapping into the openings on either side of the battery base.

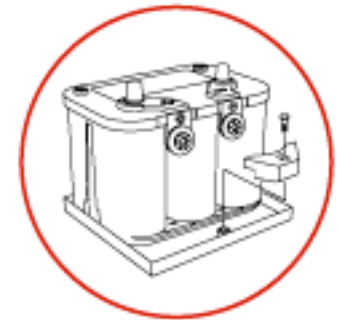

## OPTIMA GROUP 34/78

The optional puck adapter is required for most GM installations where the side terminals are used. Position the puck against the center cylinder of the battery and bolt to the battery tray as shown.

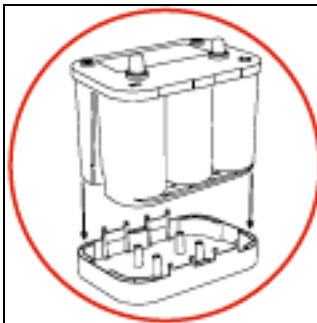

## OPTIMA GROUP 34/78

The optional red or yellow height adapters may be used for installations where a group 24 is required. Place the battery securely on top of the adapter until the clips snap into place.



## Optima Group 75/25/35

The wing adapters are attached to the ends of the battery to provide a hold down area for DIN H5 applications. Attach the wing adapters by snapping them into the openings on either end of the battery.